

OZ THEATRE SCREENS

7th June 2006 - FOR IMMEDIATE RELEASE.

Oz Theatre Screens is proud to bring you the new and improved Majestic Fixed Frame projection screen. What's been improved on the Majestic ? The frame is now a sleek and elegant beveled edge shape with curves in all the right places.

Doing away with the already innovative diamond tensioning system, we have come up with what we think is the best fabric attachment system ever conceived. *Screen Grip* is the newest and easiest to use fabric attachment system around. This patented method secures the screen fabric even and tight resulting in the flattest screen on the market.

If you are looking for a quick and effective pain free assembly look no further.

Screen Grip is, by far, the easiest attachment method ever conceived. And takes no more than 10 minutes to attach the fabric to the frame. *Screen Grip* works by pushing the bulbous head of the *Screen Grip* strip past a narrower opening in the extrusion itself, it then rests in it's holder with the fabric in between. See diagram below.

One small piece of *Screen Grip* is placed on each corner to hold the fabric in place. Then it's as easy as popping in the rigid *Screen Grip* strips around the perimeter of the frame and cutting off any excess fabric. It really is that simple. *Screen Grip* tensions the fabric for you. Gone are the days of menacing grip systems that leave you sweating and frustrated. No more relying on perfecting various grip methods which only take up too much time and leave your expensive projection fabric damaged if the need arises to take it out. *Screen grip* will not damage your fabric because of it's rounded profile. *Screen Grip* is the perfect attachment system.

Screen Grip will allow you to achieve a perfectly tensioned screen on your first attempt. This new fabric attachment systems comes out of almost 2 years R&D. The Majestic is now set to become the benchmark fixed frame screen for the Australian AV Industry. Available from the 1st of July 2006

*"So easy,
so effective"*

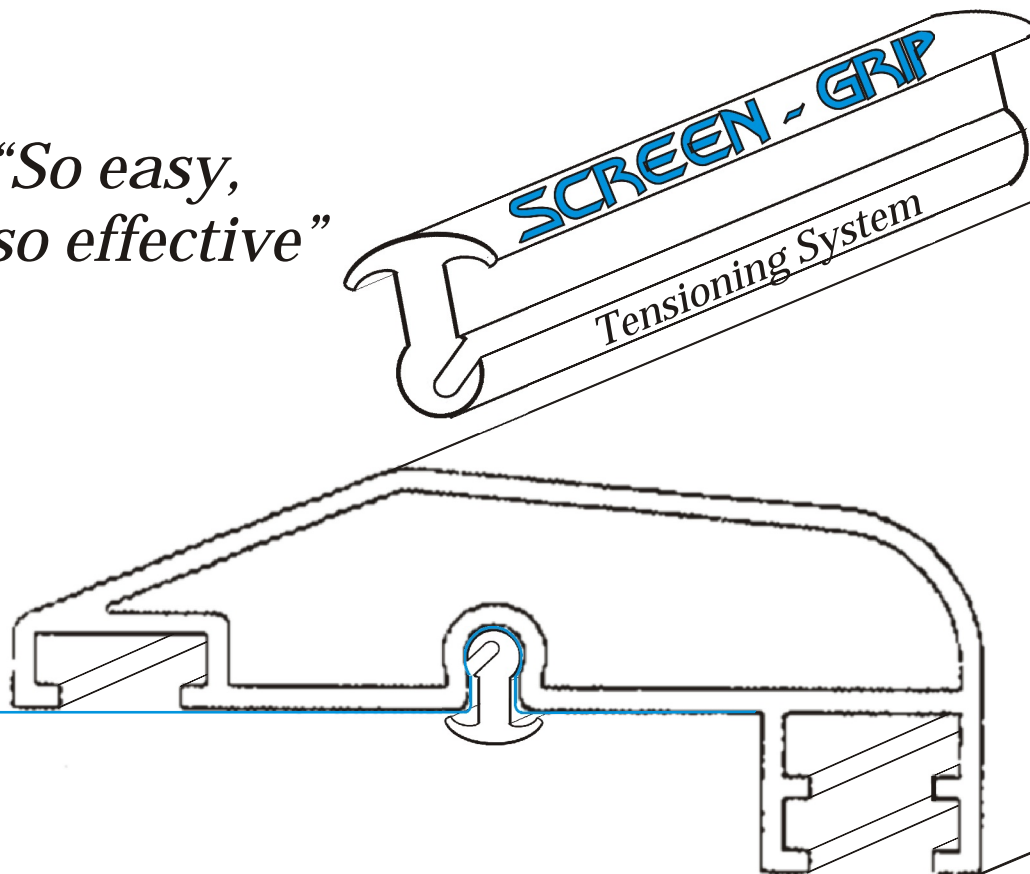

Australian and International Patent Pending
Copyright © 2006 Oz Theatre Screens